

Remote Start/Stop Module

SPECIFICATIONS

1-877-912-6605 | www.vmacair.com



Remote Start/Stop 3550750

SPECIFICATIONS

The VMAC Remote Start/Stop Module for 2007-2009 Dodge 6.7L 2500-5500 Automatic Transmissions and 2007-2009 Sterling Bullet 6.7L 3500-5500 Automatic Transmissions allows easier remote start/stop integration. With the vehicle key in the RUN position, the module allows the starter to be engaged remotely. Ideal for bucket truck operators or any work truck requiring a remote engine start.

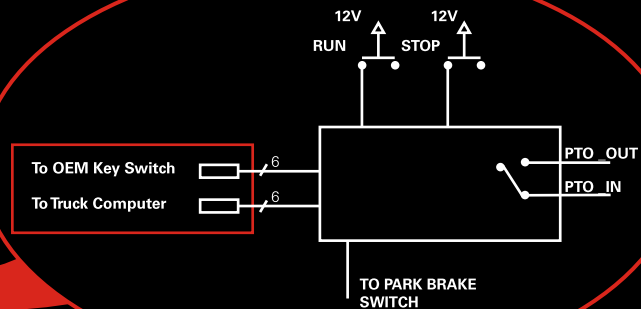
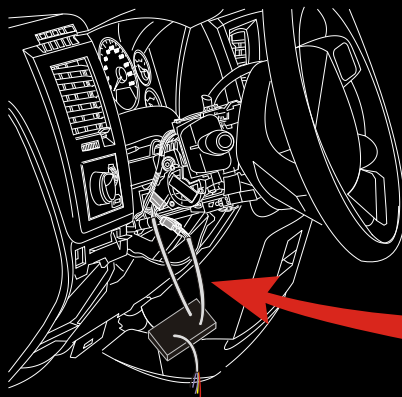

BENEFITS

- Reduces complexity of installing remote start/stop
- All day use versus OEM limitations
- Can eliminate extra PTO-engage switch
- Designed to work with ignition on
- Parking brake requirement safety function
- Designed to work with air-actuated electronic controls for bucket trucks
- Designed to work with electric momentary switches
- Interacts with Dodge's Remote Start functions

